



ZEROWELD™

Easy, Secure  
Efficient.

# About:

Introducing the ZeroWeld bracket range, a revolutionary solution that eliminates the need for welding in various applications. These cutting-edge brackets are designed to securely hold and connect components without the time-consuming and complex welding process. With their unique design and functionality, Zero Weld Brackets open a new realm of possibilities for professionals in various industries.



Crafted with 16Ga galvanised grade C250 steel, AUSTek's Zero Weld brackets feature a robust and durable construction, ensuring exceptional strength and reliability. They are engineered to comply with Australian standards. They will withstand heavy loads, vibrations, and other demanding conditions, making it ideal for applications where traditional welding may pose challenges.

One of the key advantages of Zero Weld brackets are their simplicity of installation. Unlike welding, which requires specialized equipment, training, and safety measures, Zero Weld brackets offer a hassle-free installation process. Simply align the components and secure them using Zero Weld brackets, reducing both the time and effort required to complete a project

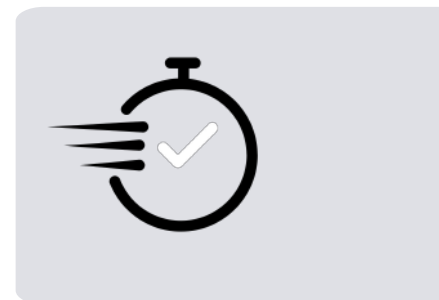

The versatility of Zero Weld brackets is another remarkable aspect. They can be employed in numerous industries, including construction and even DIY projects. Whether you need to connect metal frames, support structures, or intricate assemblies, Zero Weld brackets provide a reliable and efficient solution.

# ZW

For joining AUSBEAM, RHS (Rectangular Hollow Section), SHS (Square Hollow Section) or C-Section on a 0 to 5 degree pitch.

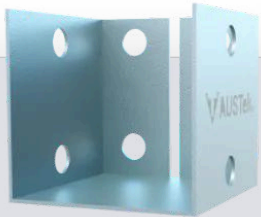

**ZW50**

Dimensions: 2x2 Inch  
 Thickness: 16Ga  
 Max Load: 9.00 kN



**ZW75**

Dimensions: 2x3 Inch  
 Thickness: 16Ga  
 Max Load: 9.72 kN



**ZW100**

Dimensions: 2x4 Inch  
 Thickness: 16Ga  
 Max Load: 9.75 kN

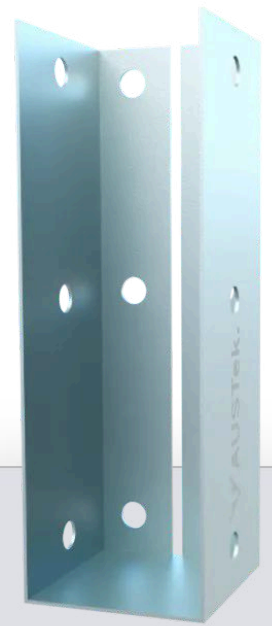

**ZW150**

Dimensions: 2x6 Inch  
 Thickness: 16Ga  
 Max Load: 10.42 kN

## Recommended Fasteners:

When using ZW brackets, it is crucial to employ a minimum of 8 gauge Metal Tek's for optimal performance.

## Australian Standards:

**AS4600:** Cold-formed Steel Structures  
**AS1170.0:** General Principles  
**AS1170.1:** Dead and Live Load

# JZW

For joining AUSBEAM or RHS (Rectangular Hollow Section) Bearers to joist.



## JZW75

**Dimensions:** 2x5 Inch  
**Suits:** 2x3 Inch Joist  
**Thickness:** 16Ga  
**Max Load:** 16.20 kN



## JZW100

**Dimensions:** 2x6 Inch  
**Suits:** 2x4 Inch Joist  
**Thickness:** 16Ga  
**Max Load:** 17.38 kN

### Recommended Fasteners:

When using JZW brackets, it is crucial to employ a minimum of 8 gauge Metal Tekes for optimal performance.

### Australian Standards:

**AS4600:** Cold-formed Steel Structures  
**AS1170.0:** General Principles  
**AS1170.1:** Dead and Live Load

# PZW

For joining AUSBEAM, RHS (Rectangular Hollow Section), or C-Section on a 22 or 15 degree pitch.



**PZW15-100**

Dimensions: 2x4 Inch  
 Pitch: 15 Deg  
 Thickness: 16Ga  
 Max Load: 9.70 kN



**PZW15-150**

Dimensions: 2x6 Inch  
 Pitch: 15 Deg  
 Thickness: 16Ga  
 Max Load: 14.58 kN



**PZW22-100**

Dimensions: 2x4 Inch  
 Pitch: 22 Deg  
 Thickness: 16Ga  
 Max Load: 9.70 kN



**PZW22-150**

Dimensions: 2x6 Inch  
 Pitch: 22 Deg  
 Thickness: 16Ga  
 Max Load: 14.58 kN

## Recommended Fasteners:

When using PZW brackets, it is crucial to employ a minimum of 8 gauge Metal Tek's for optimal performance.

## Australian Standards:

AS4600: Cold-formed Steel Structures  
 AS1170.0: General Principles  
 AS1170.1: Dead and Live Load

# AZW

For joining AUSBEAM or RHS (Rectangular Hollow Section), at the apex with a 22 or 15 degree pitch.

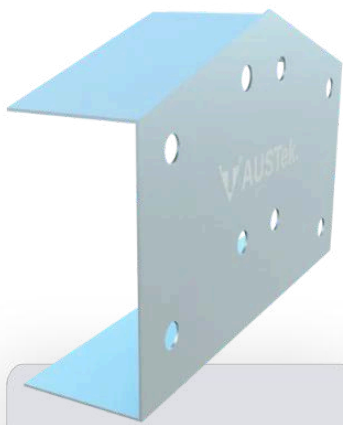

## AZW15-100

Dimensions: 2x4 Inch  
Pitch: 15 Deg  
Thickness: 16Ga  
Max Load: 1.01 kNm

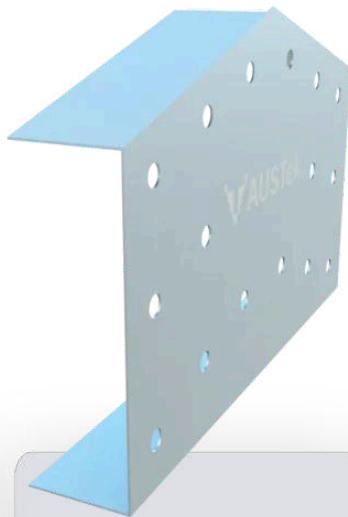

## AZW15-150

Dimensions: 2x6 Inch  
Pitch: 15 Deg  
Thickness: 16Ga  
Max Load: 2.31 kNm

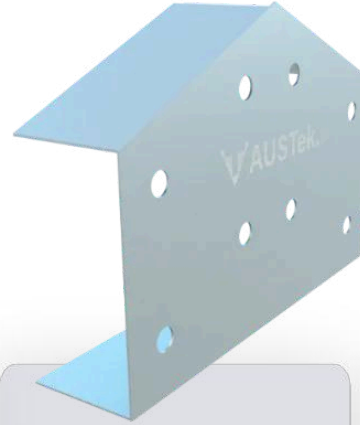

## AZW22-100

Dimensions: 2x4 Inch  
Pitch: 22 Deg  
Thickness: 16Ga  
Max Load: 1.30 kNm

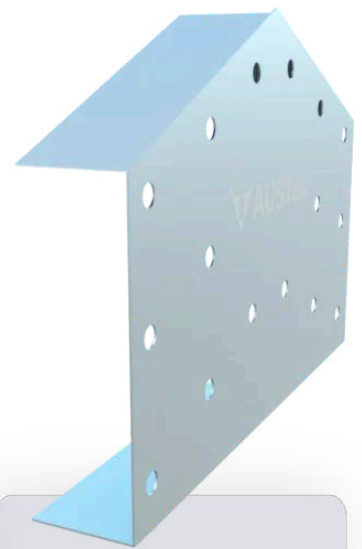

## AZW22-150

Dimensions: 2x6 Inch  
Pitch: 22 Deg  
Thickness: 16Ga  
Max Load: 2.85 kNm

### Recommended Fasteners:

When using AZW brackets, it is crucial to employ a minimum of 8 gauge Metal Tek's for optimal performance.

### Australian Standards:

AS4600: Cold-formed Steel Structures  
AS1170.0: General Principles  
AS1170.1: Dead and Live Load

# JZW Installation

## STEP 1:

Screw JZW bracket in place using all screw holes using a minimum of 8 gauge metal teks.

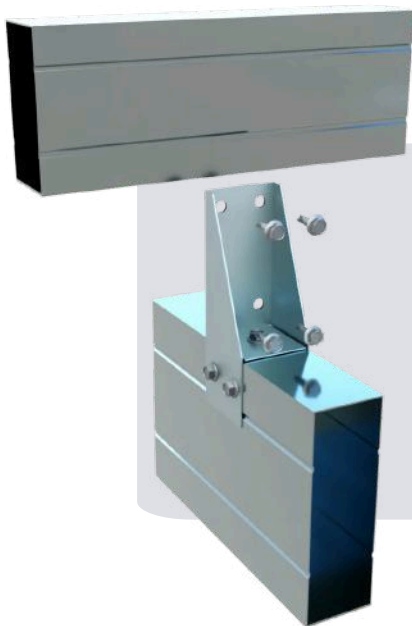

## STEP 2:

Place AUSBEAM or RHS joist onto the bearer in front of JZW bracket.



## STEP 3:

Screw all remaining holes using a minimum of 8 gauge metal teks to complete.

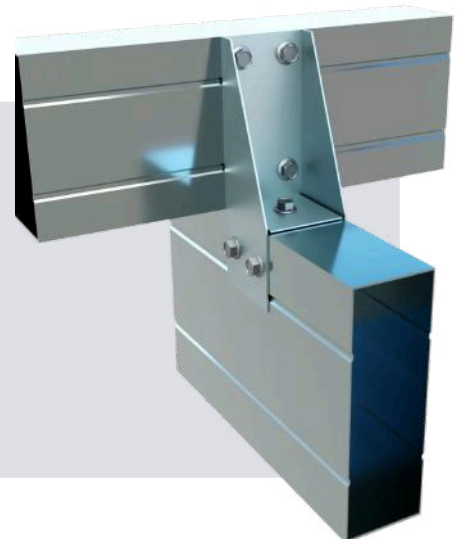

# ZW Installation

## STEP 1:

Screw ZW bracket in place using all back screw holes using a minimum of 8 gauge metal teks.

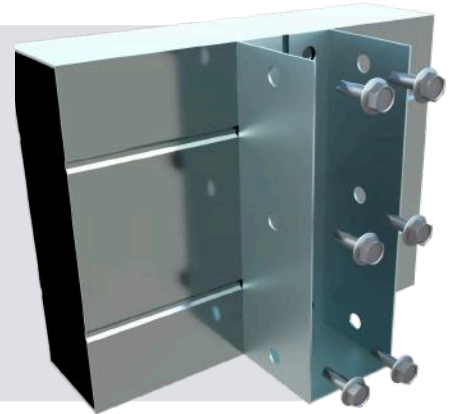

## STEP 2:

Place AUSBEAM or RHS into ZW bracket.



## STEP 3:

Screw all side screw holes using a minimum of 8 gauge metal teks to complete.



# PZW Installation

## STEP 1:

Screw PZW bracket in place using all back screw holes using a minimum of 8 gauge metal teks.

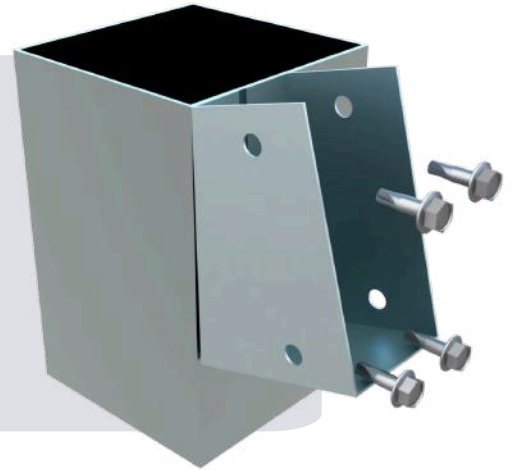

## STEP 2:

Place AUSBELM or RHS into PZW bracket.

## STEP 3:

Screw all side screw holes using a minimum of 8 gauge metal teks to complete.

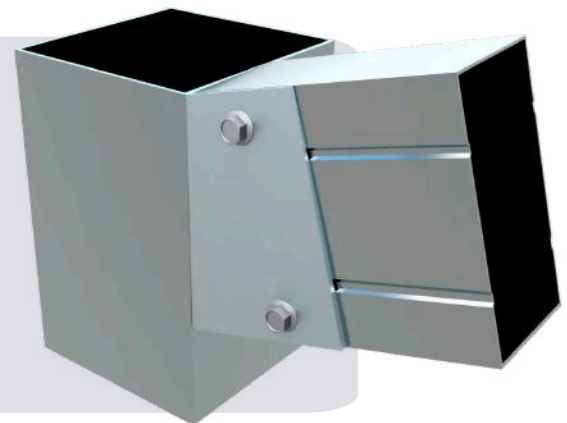

# AZW Installation

## STEP 1:

Place AZW bracket over apex join (on the ground or with rafters in position)

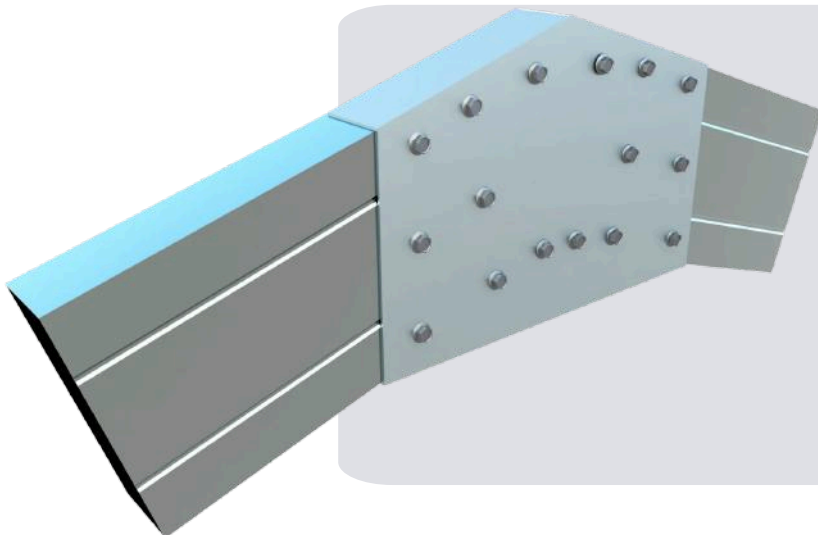
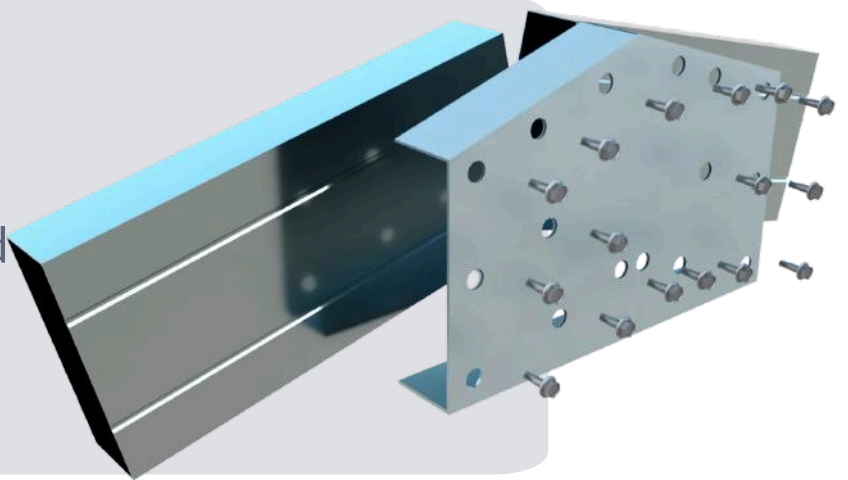

## STEP 2:

Screw AZW bracket in position with a minimum of 8 gauge metal teks using all screw holes.

# Universal Use:

ZeroWeld brackets versatility extends over a massive range of structures as well, offering robust support and flexibility for a variety of construction projects. Here's a description of smaller structures that can be built using ZeroWeld brackets:

**Gazebos and Pergolas:** For outdoor living spaces, ZeroWeld brackets provide an ideal solution for building gazebos, pergolas, and other shade structures. Engineered and manufactured to withstand exposure to the elements whilst providing a strong, durable, and sleek design.

**Subfloors and Decks:** ZeroWeld brackets offer a versatile solution for subfloor and decks. Whether constructing subfloors for buildings, elevated decks for outdoor spaces, or composite decking systems, ZeroWeld brackets ensure durability and stability. Additionally, their use in modular flooring systems and as underlayment for flooring installations highlights their adaptability and ease of installation.

**Small Commercial Structures:** ZeroWeld brackets are suitable for small-scale commercial construction projects, including small public toilets, bus stop shelters, and park pavilions. Their versatility and durability allow for the creation of many customizable structures that meet the specific needs of businesses and organizations.

**Sheds and Carports:** ZeroWeld brackets offer an efficient and durable solution for building sheds and carports. Their lightweight construction simplifies assembly, while their strength and durability provide secure storage for tools, equipment, and vehicles, protecting them from the elements.

**Agricultural Structures:** In rural settings, ZeroWeld brackets can be used to construct agricultural buildings such as barns, stables, and equipment shelters. Their versatility and durability make them an ideal choice for protecting livestock, storing hay and feed, and housing farm machinery, ensuring the efficient operation of agricultural operations.

The design of ZeroWeld brackets is protected by design rights owned by Austek Brackets. Any unauthorized replication, imitation or use of the distinctive features, shapes or configurations of ZeroWeld brackets without prior written permission from Austek Brackets is strictly prohibited.



[www.austek.co](http://www.austek.co)